

**Detail & Submittal Sheet**

**Construction Specifications:**

**Heavy Duty** Outdoor Cabinet is made from 16 gauge galvanized steel in a baked red acrylic enamel over phosphate treated steel. It includes weather resistive gasketing, full length stainless steel piano hinge with 2 roller ball catches, safety lock, a sloped roof to facilitate drainage, white "Fire

Extinguisher" decal, "Pull Firmly to Open" decal, and stainless steel pull handle.

Project: \_\_\_\_\_

Specification Reference: \_\_\_\_\_

Model Number: \_\_\_\_\_ Quantity: \_\_\_\_\_

Architect: \_\_\_\_\_

Contractor: \_\_\_\_\_

Distributor: \_\_\_\_\_

Approved By: \_\_\_\_\_

Date: \_\_\_\_\_

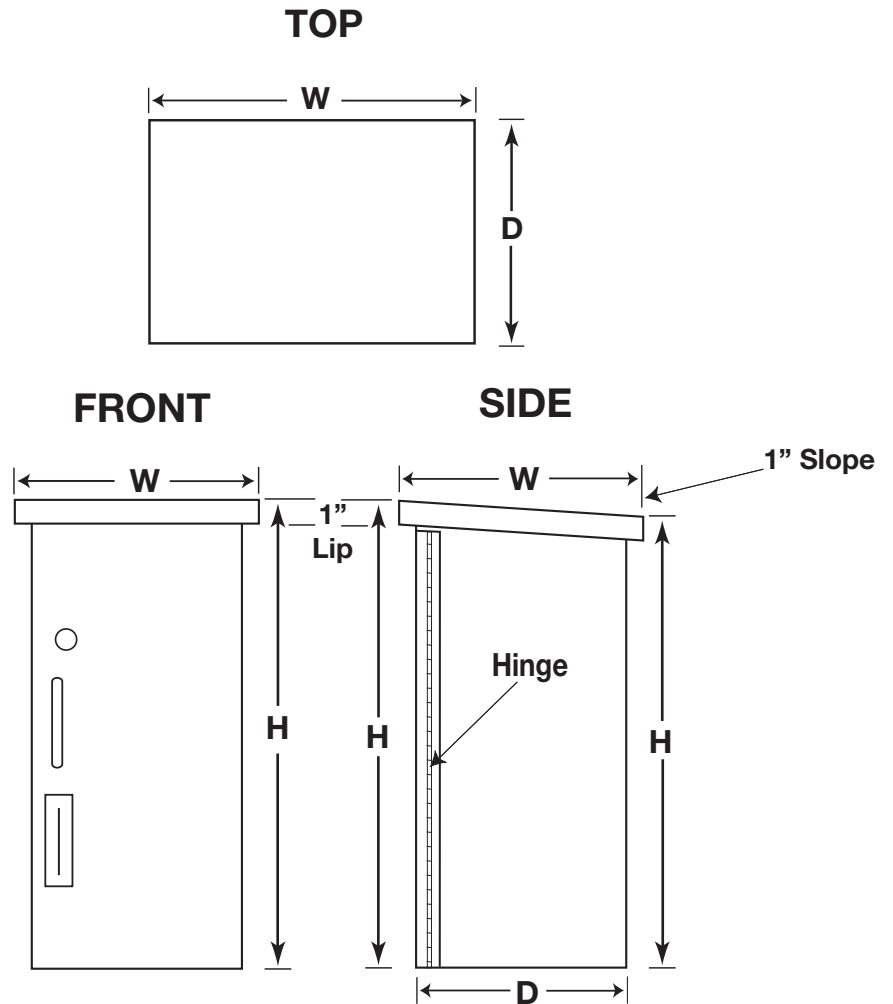
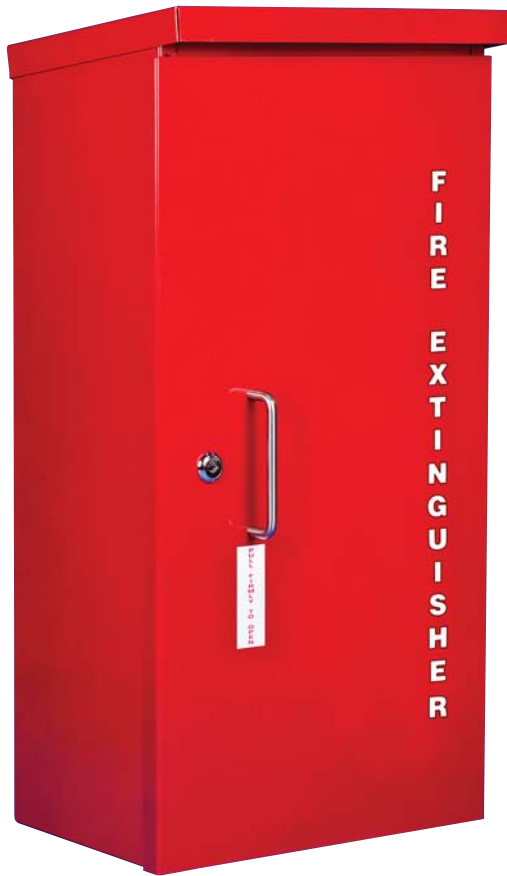

| ✓                         | Mod. #         | Trim Style | Interior Tub Size |     |        | Overall Outside Trim |     | Shipping Weight | Accom. Ext. Size |
|---------------------------|----------------|------------|-------------------|-----|--------|----------------------|-----|-----------------|------------------|
|                           |                |            | W                 | H   | D      | W                    | H   |                 |                  |
| <b>Heavy Duty Outdoor</b> |                |            |                   |     |        |                      |     |                 |                  |
|                           | <b>HDOC-10</b> | -          | 11 1/2"           | 24" | 7 3/4" | 12"                  | 25" | 30              | 5 & 10           |
|                           | <b>HDOC-20</b> | -          | 14"               | 28" | 9"     | 14"                  | 28" | 35              | 20               |
|                           | <b>HDOC-30</b> | -          | 14"               | 33" | 9"     | 14"                  | 33" | 40              | 30               |