

Detail & Submittal Sheet

Construction Specifications:

CM1101-Outdoor Hose Storage cabinet, constructed of 16 ga. satin coat galvanized metal with two coats red baked enamel. Stainless steel piano hinges with chrome plated door latches. Used to store fire hose and equipment for outdoor use in industrial applications.

Product Features:

- 16 ga. galvanized steel sheet throughout, weighs 250lbs
- Empty shelves 13" wide with 3/4" lip
- 2" slope on roof
- Rain trough over doors
- Door reinforcement at front, top and bottom
- Doors overlap tub at hinge side
- Piano hinge on both doors
- Door lock (R.H. door only)
- Chrome plated handle with 2 point catch

- Louvers on each end under bottom shelf (optional—please specify)
- Inside lips (front side)
- 3" at top 1 1/2" at bottom
- 1" at sides and bottom
- Two coats red baked enamel

To Specify:

- Wall Mounted (with rear lugs top & bottom)
- Concrete Base Mounted (with grouting lugs at bottom)
- Support Mounted - legs packed separately (Steel fabricated legs available 24", or 36")

Options:

- Additional shelves upon request
- Suitable brackets for Accessories
- "Fire Hose" Decal

Project: _____

Specification Reference: _____

Model Number: _____ Quantity: _____

Architect: _____

Contractor: _____

Distributor: _____

Approved By: _____

Date: _____

Please Note: Not suitable for sea water environment. We reserve the right to alter cabinet specifications and dimensions. Please contact our local representative for updated approval drawings prior to base construction and ordering.

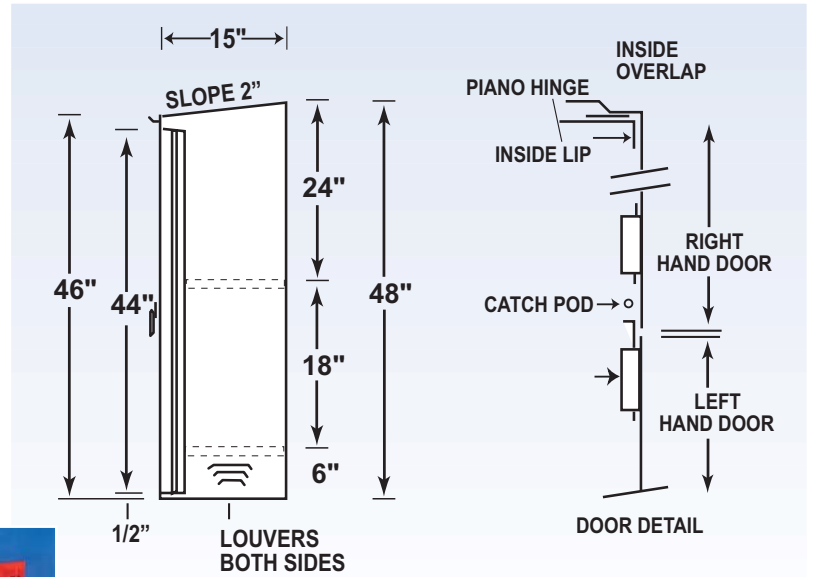
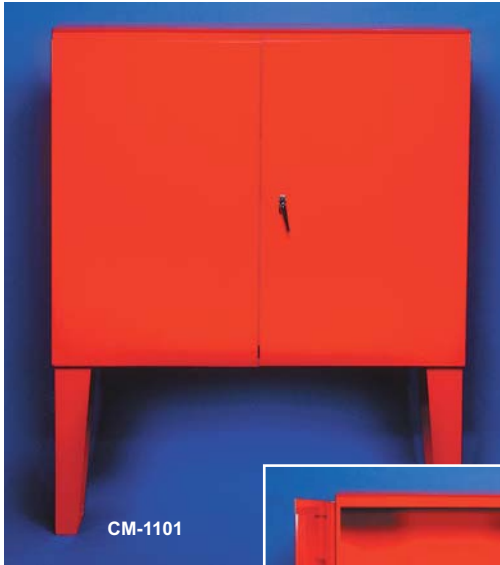

✓	Mod. #	Description	Height	Shipping Weight
Lbs				
Outdoor Weather Proof Hose Storage Cabinet				
	CM1101	Weatherproof Hose & Storage Cabinet - w/12" legs (standard)	60"	250
	CM1101-24	Weatherproof Hose & Storage Cabinet - w/24" legs	72"	255
	CM1101-36	Weatherproof Hose & Storage Cabinet - w/36" legs	84"	265